

Alimentatore 12V 480 W IP20 SP

Cod. 112064



Alimentatore adatto ad installazioni in interno con contatti a vista raffreddato a convezione d'aria con ventilazione

Caratteristiche tecniche

W potenza
480

A corrente
40,0 A

protezione
IP20

applicazione
interno

V_{in} tensione Ingresso
85-265 Vac

V_{out} tensione Uscita
12 V

Ventilato
SI

Caratteristiche geometriche

 Dimensioni (mm)
(278 x 127 x 43)

Le immagini del prodotto sono di riferimento

Tutte le indicazioni riportate non sono vincolanti e possono essere soggette a modifiche, anche senza preavviso.

Mechanical Specification

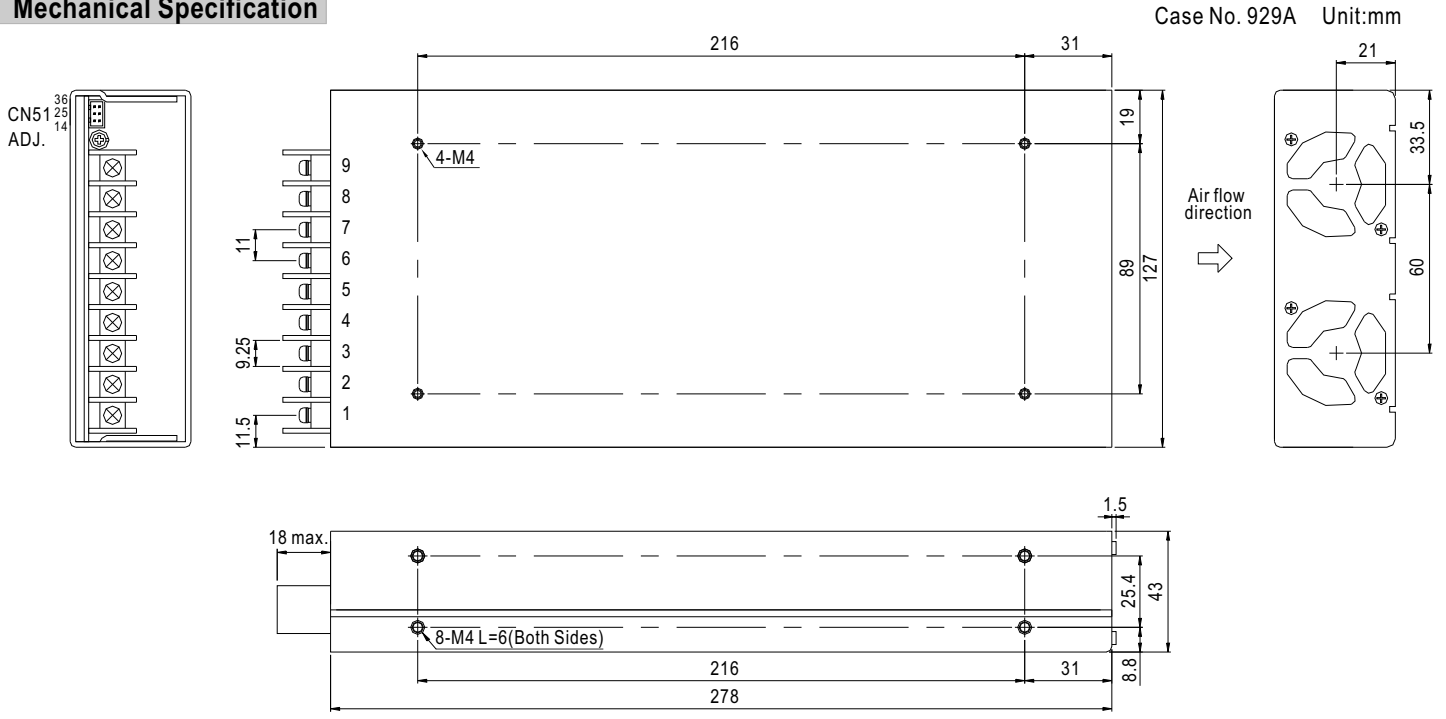

Case No. 929A Unit:mm

Terminal Pin No. Assignment :

Pin No.	Assignment	Pin No.	Assignment
1	AC/L	4~6	-V
2	AC/N	7~9	+V
3	FG \perp		

Connector Pin No. Assignment (CN51) : HRS DF11-6DP-2DS or equivalent

Pin No.	Assignment	Pin No.	Assignment	Mating Housing	Terminal
1	GND	4	N.C.	HRS DF11-6DS or equivalent	HRS DF11-**SC or equivalent
2	RC-	5	RC+		
3	-S	6	+S		

Block Diagram

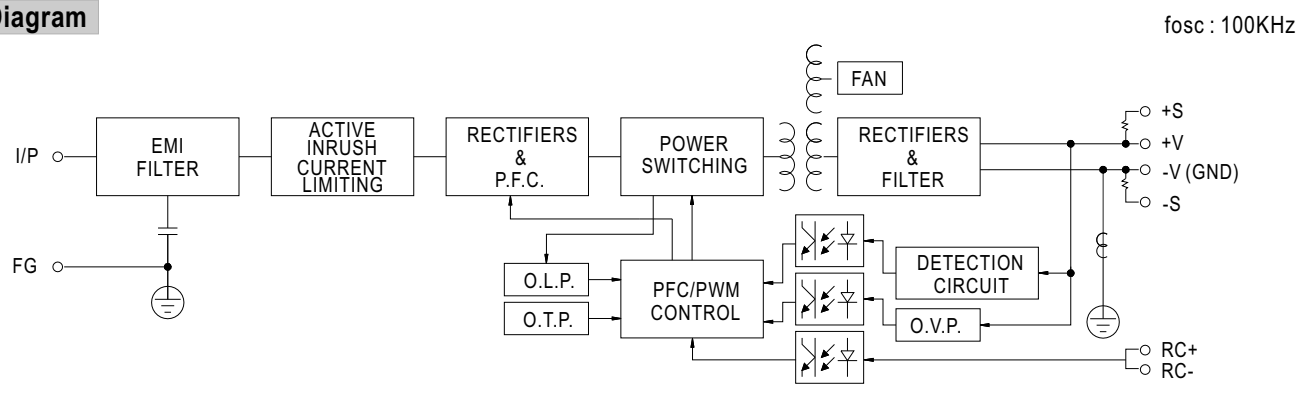

Derating Curve

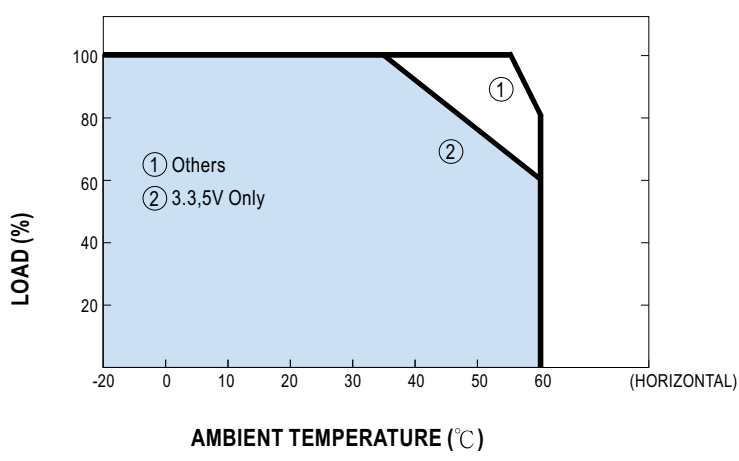

Static Characteristics

